

# Powermat

1200



**WEINIG**



# Powermat

## 1200

### **With wood into the future**

Solid wood processing with WEINIG 4

### **The whole range**

Planing, profiling and sawing in WEINIG quality 10

### **Your new workstation**

Man and machine as one entity 22

### **The Powermat 1200**

Flexible and cost-effective top technology 24

### **Machine, Tool, System**

The concept for top results 30

### **Even more possibilities**

Configuration options for the Powermat 1200 34

### **The Powermat 1200 in facts and figures**

Technology, standards and options 60



# With wood into the future

The natural feel and noble look of wooden products makes them very desirable. This renewable, eco-friendly raw material is highly valued in society. Good times for wood workers. Good times for you.

The increasing importance of wood is characterized by an ever growing field of application: Traditional fields of activity such as interior fittings, commercial furnishings and window manufacturing have been joined by imposing wooden architecture. Sophisticated façade and bridge constructions, glulam or cross laminated timber elements are enjoying increasing use in construction. Textured surfaces and creative lightweight construction are setting popular trends.

As a company active in this industry, you can benefit from this development towards increased use of wood, the only CO<sub>2</sub> neutral material. Make your decision for sustainable technology as well when choosing production machinery. WEINIG is the only manufacturer who is fully committed to solid wood processing. With passion and dedication, like yourself. The ideal partner for innovative concepts to help you conquer tomorrow's market. WEINIG's machines have an especially long service life and offer exceptional reliability. An investment in WEINIG's production technology has long term benefits and means security for your company. Very short set up times and maximum material yield are built into every solution. Naturally with perfect accuracy of dimensions and excellent surface quality for your products.

Planing, profiling, texturing. Whatever you do – you will always make the right choice with machines from WEINIG.



# WEINIG offers more

WEINIG's successful path in wood processing is characterized by listening to our customers and the demands of the market place. Born from many years of experience, WEINIG's R & D department never fails to create new practical solutions for industry and small shops. Whoever buys a WEINIG machine today knows that they are optimally equipped for the future of their business.

**100% quality** – WEINIG's machines have to satisfy the most difficult requirements. That is why great care in product development and manufacturing is a tradition at WEINIG. You benefit from this by the long service life of your valuable investment.

**Reliability** – The availability of a machine determines how profitable your business is. WEINIG is known for their high standard in technology. More than 80,000 machines from WEINIG are operating around the globe to the utmost satisfaction of our customers.

**Expert advice** – Whether you need expertise of WEINIG Concept for turn-key solutions or the know-how of a WEINIG expert at your door – you can always rely on our committed sales team. Ultimately you will have a customized solution that offers you maximum value for your investment.

**Everything from a single source** – In WEINIG you have an experienced full service provider as your partner. From rough cutting to stacking, from a stand-alone machine to a fully automated turnkey production line. Including, of course, a comprehensive service package.

**Service** – Safety is reassuring. In the case of need, our trained service engineers will be quickly on site. WEINIG maintains a unique closely woven service network worldwide. It is so closely woven that no customer can fall through!

**The WEINIG ExpoCenter.** In our ExpoCenter we can show you what top technology can really do for you. Here you can experience our machines in action.



Give your business  
a new perspective...





## ...when profiling

Profitability is more than the number of feed rollers. Behind every high performance machine there must be a design concept that puts you in a leading position to control costs, guaranty delivery and cater to the customers' wishes. WEINIG production technology is geared specifically to this approach. Perfectly adapted to individual circumstances such as market situation, batch sizes and internal working conditions.

From us you receive a solution that offers maximum return on investment. WEINIG's innovative technology ensures that your setup times are shortened, your reject rates drop and process reliability is guaranteed throughout. As a full service provider, we can also give you a total package so that you can organize the machine environment perfectly. From job preparation to the finished quality product. This means you can control logistic processes better, streamline order flow and ultimately improve the labor cost component of your products.

Profitable profiling has a name - WEINIG.

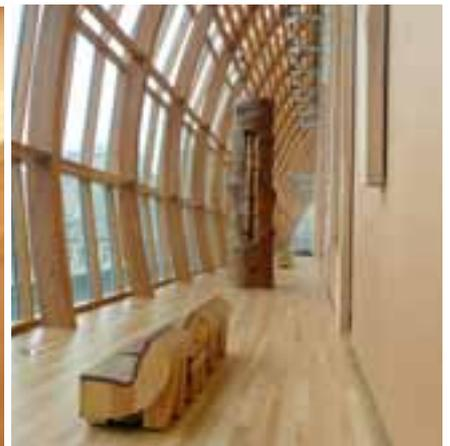



# ...for window production

Whether a single workpiece or series production. Profitability in window production starts with planing all four sides. With WEINIG you are setting the right course. As an experienced specialist for complex window production systems, we know what must come out at the end of the process to ensure your profitability.

Therefore, you can not only plane scantlings on your moulder, but also produce all mouldings necessary in window production. And of course with a level of flexibility which fulfills the growing demands on window systems in every respect. With the advantage of minimum setup times and shorter throughput times, your moulder is ideally matched to realize the full potential of the window production line. From a standpoint of economics, it doesn't get any better!



# Profiling: You can't copy experience

We are not the only one who manufactures moulders. But we are the only ones with the experience of over 80,000 units worldwide. And the valuable feedback that we gather from continuous discussions with our customers is incorporated into each new WEINIG machine.

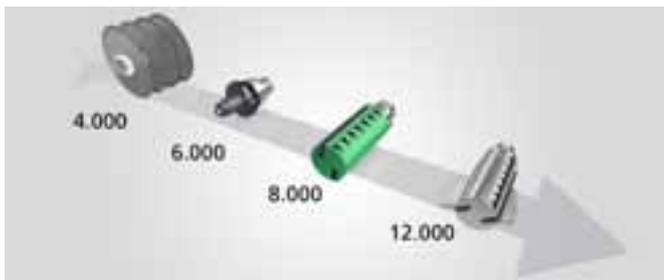

## Expertise in speed

As a manufacturer with our own tool production, we know all about rpm requirements and match the tool characteristics to suit the machine ideally.

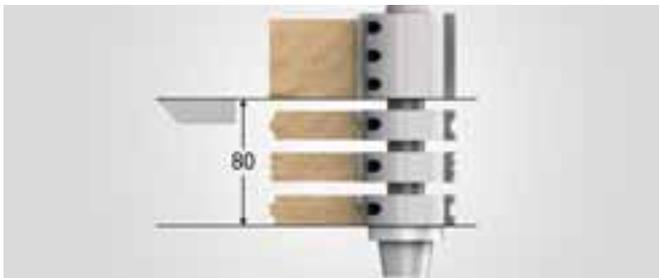

## Expertise in profile splitting

Efficient profiling is a combination of machine positioning and tool technology. With CNC controlled axial adjustments it is possible to produce multiple profiles without changing the tools.



80,000 moulders also means we can offer expertise in an enormous range of applications. From mouldings to beams; we have given every product an all-round finish. Always with perfect results in typical WEINIG quality.



#### **Expertise in controlling and guiding**

To achieve ideal interaction between the tool and the work-piece, the very highest precision is required from the machine. WEINIG processing technology ensures absolute control of the workpieces during every stage of the process.



#### **Expertise in quick setting systems**

Pressure elements and extraction hood can be adjusted very simply on your WEINIG moulder to suit the cutting circle of each tool. A control system and axes is available which guarantees easy and accurate reproduction of any profile.

# Profiling: Expertise in in a big way

Where heavy solid beams are forced into motion and being processed, a solid machine base is required. Especially if a workpiece in WEINIG quality is to appear at the end. That is why our designers gave the Powermat 1200 a heavy cast iron frame. High motor performance,

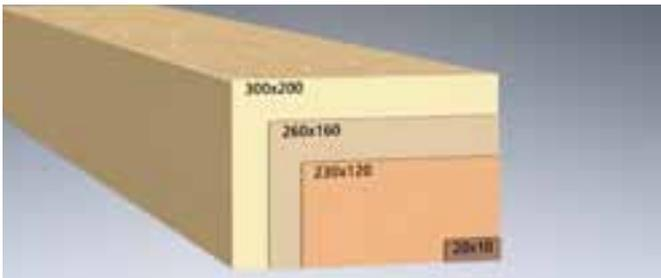

## Expertise in large and small

WEINIG can draw on its know-how in all applications. We have the right solution for moulding manufacturers, but also for producers of construction timber with cross sections up to 300 x 200 mm.



## Expertise in process technology

WEINIG processing technology means that the tool adapts to the size when milling and planing. A change in size does not require a change of tools and hence no change-over time.



exceptional rigidity of the PowerLock HSK tool system and controlled guidance of the workpiece across the full width provide ideal conditions for perfect processing of large wood pieces.



#### **Expertise in tools**

The proven WEINIG PowerLock tool system shows its great value with large sizes: No outboard bearing is needed for working widths up to 300 mm (11.81")! This means even less setup time.



#### **Expertise in profile table plate systems**

WEINIG's know-how makes transporting workpieces even more dependable. An air pad system is used to reduce friction. This makes the machine less susceptible to stoppages and results in less waste.

# Window production: Quality begins with the moulder

With the Powermat 1200 you can use the full capability of a WEINIG moulder for window production as well. Whether four sided planing, removal of glazing beads or profiling with an excellent surface quality - the Powermat is ideally suited for every task. The whole process-



## Expertise in workpiece finishes

A special sharpening process developed by WEINIG ensures very high quality surface quality and extends the service life of tools. Tools can be sharpened up to 10 times without having to be changed.



## Expertise in short workpieces

The concept of single piece production has made this possible: even short work pieces can be conveyed reliably through the machine. It works perfectly with WEINIG's short piece package.



ing sequence is performed without any manual intervention – without setup time! Intelligent control technology ensures profitability even for a single workpiece and offers the best prerequisites for integration in your window production systems.



#### **Expertise in wood optimization**

Making more out of wood is a leading principle of WEINIG. With the Powermat the press of a button is enough to remove a glazing bead while the workpiece is being planed.



#### **Expertise in guide systems**

With a quick positioning pressure shoe and a pneumatically positioned guiding fence, it is possible to select on screen for glazing bead removal or not.

# Window production: A large variety of glazing beads made easy



Four sided planing, glazing bead removal and profiling are by no means the extent of the Powermat's capabilities. Make use of this versatile machine for cost effective manufacturing of all your win-

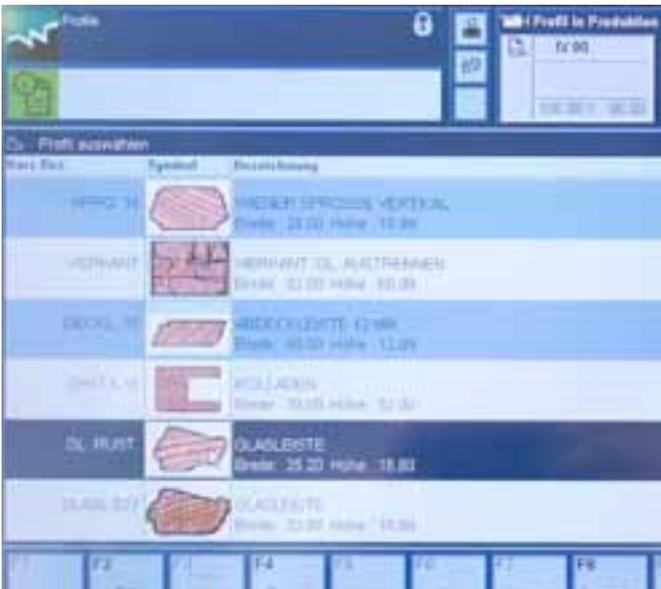

## Expertise in control systems

It is the PowerCom Plus control system which makes the Powermat so flexible allowing you to realize all possibilities in a simple manner. Exact positioning of the NC axes ensures repeatable accuracy. Optimize your production with intelligent tool splitting.



dow moulding requirements. With WEINIG quality mouldings you will improve the look of your window and your market chances.

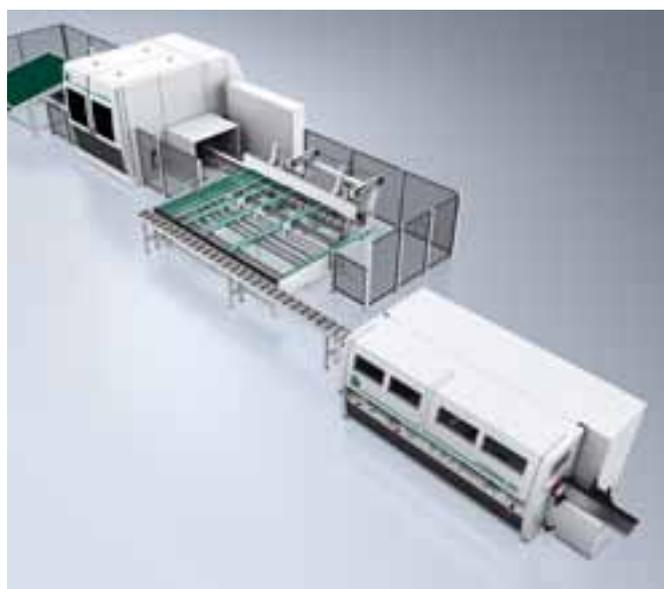
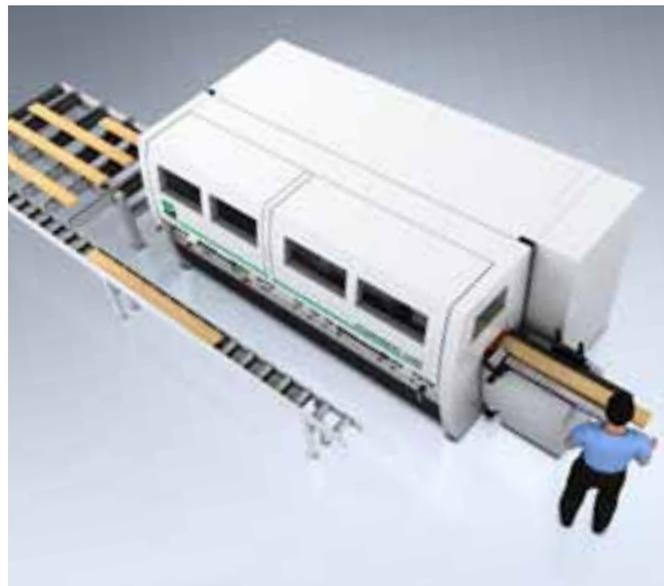

#### **Expertise in linking and automation**

For us, window production does not end with planing and profiling. As a specialist for fully automated window lines, we offer a wide range of modular solutions for complete processing which can be integrated seamlessly into the Powermat.



# Operator-friendly workstation

Ultimate design, perfect processing down to the last detail. Typical WEINIG: It's fun to work with. Somehow it's a perfect match. That isn't just any machine – it's a WEINIG Powermat 1200. Not everyone has one, of course. But everyone would like to have one. Or at least work with it. You see a slow smile spread across your face. Press the start button and the IE2 class motors power up smoothly, like turbines. You swivel control console into position. Flip open the cover and you have everything at a glance. It's like working on a laptop, but more productive. This is the modern way man to communicate with a machine. You will think it has been made just for your needs. Ergonomic design, practical, modern. Just the way you would have designed it. Of course WEINIG has packed in everything that is state-of-the-art. Safety features, noise protection. And you never lose control of things. The screens are easy to read, the color coding clear and readily understandable. One could easily fall into words of praise. At least for eight hours. And perhaps even a little longer today. It would be fun...



# WEINIG Powermat 1200: The universal value added machine

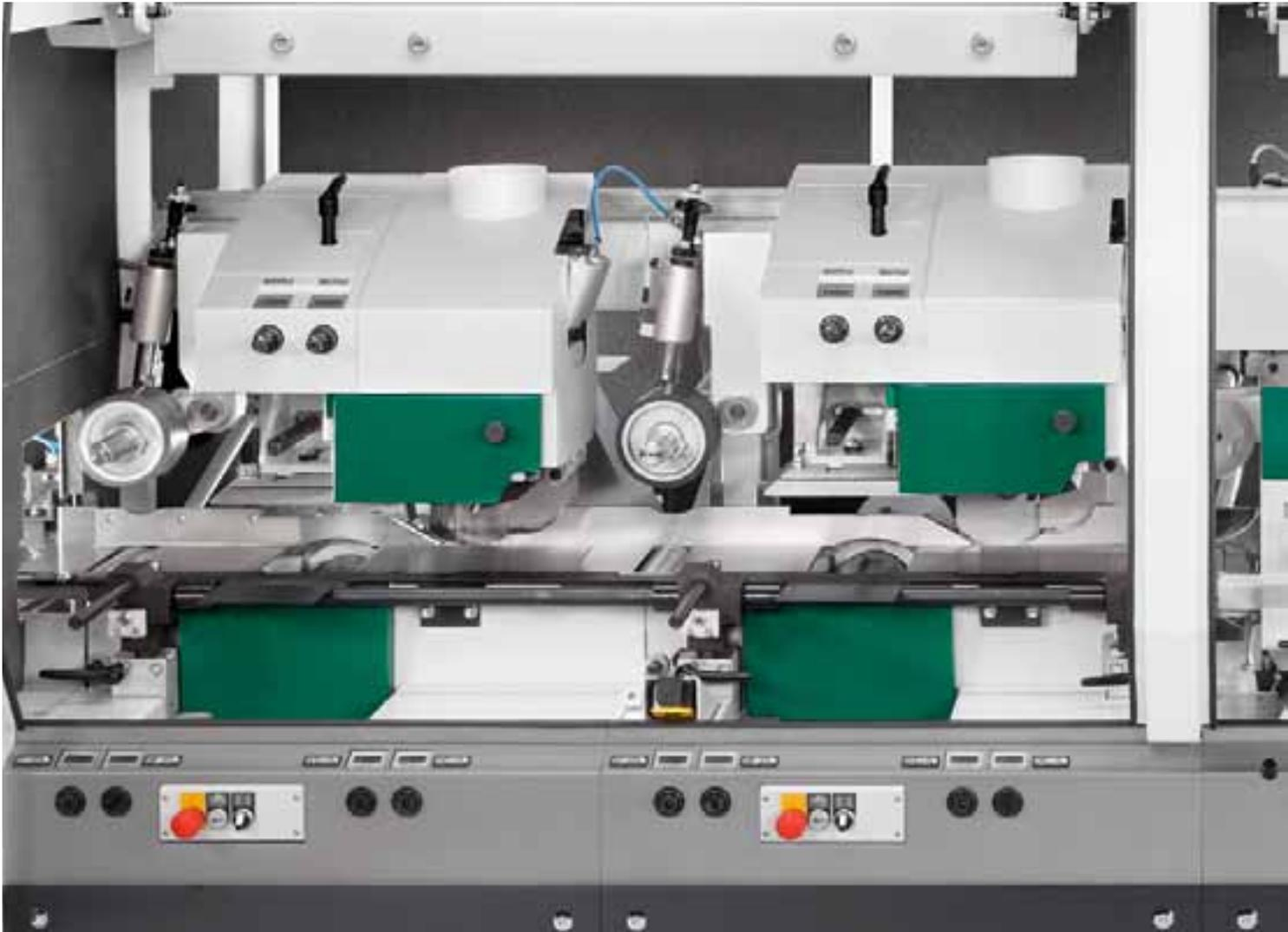

WEINIG offers an exceptional machine as a standard model. The Powermat 1200. From high quality cast iron frame to intuitive and safe operation. The latest technology, flexibility and a wide range of capabilities make the Powermat 1200 to a machine that suits nearly every modern production facility. Add top profitability, high resale value and the legendary WEINIG surface quality.



### **Spindles**

Development and production have a long tradition in our company. You can benefit from our experience of producing 35,000 spindles every year.

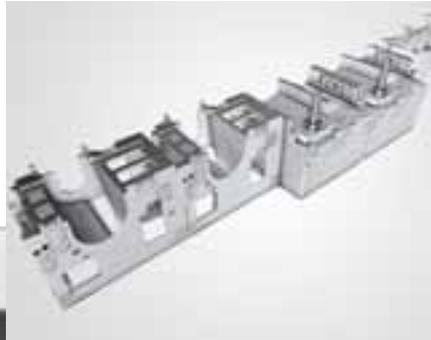

### **Cast iron frame**

We use heavy, vibration absorbing cast iron for the base of the Powermat 1200.



### **IE2 motors and EMGS**

Top performance does not exclude economy of operation. The motors of the Powermat 1200 have an intelligent Energy Management System.



- Heavy cast iron construction
- Up to 12,000 rpm
- Frequency-controlled feed speed
- WEINIG Quality
- Optimized software solutions
- Worldwide service and reliable spare parts supply

# The heart of the Powermat: It's the difference that counts

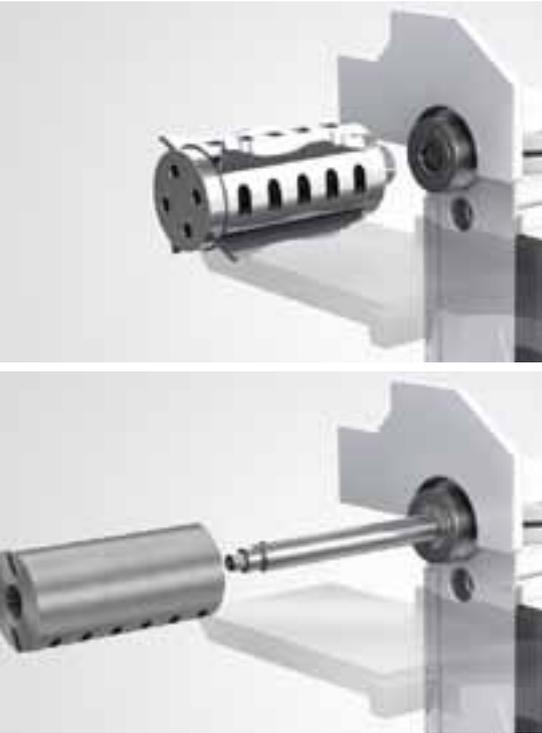

- Tool interface with PowerLock
- Conventional tool with bore

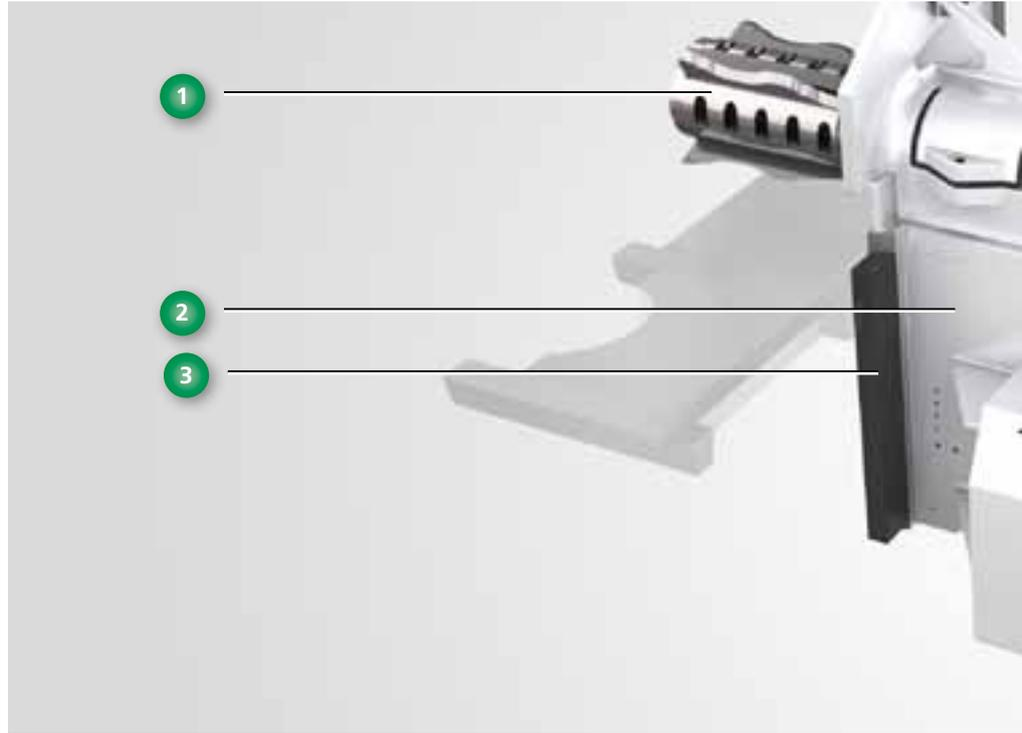

Knowledge, diligence and quality components. Only when everything is working in perfect harmony do you get a perfect result. That is why the drive unit of your WEINIG moulder is made of top quality components. And that is why top class tradesmen work in our production. From the belt tracking to the bearings to the motor flange: everything has been thought through down to the very last detail. It is the sum total of all these factors that creates the quality you need to be successful in the market - WEINIG quality.

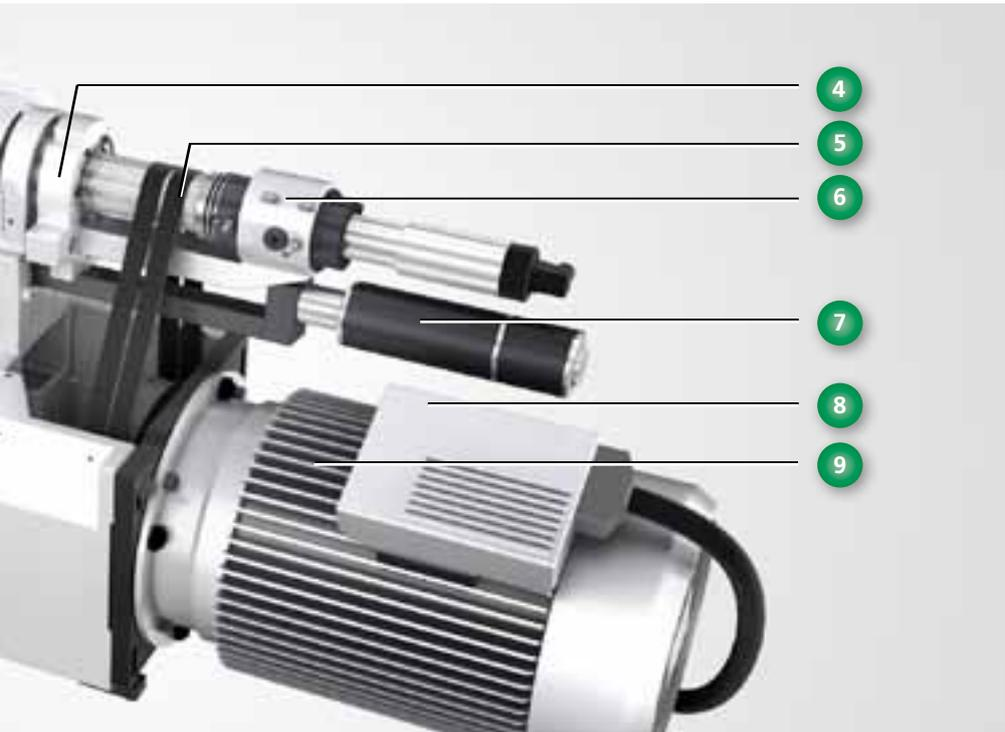

The drive unit of the Powermat 1200:

1. PowerLock tool system: Speed regulation from 4,000-12,000 rpm using a frequency converter
2. Spindle slide: the mono block design absorbs vibrations and ensures a smooth running system
3. Spindle slide with dove tail guide: adjustable
4. Spindle: High tech component with reliable, sophisticated technology
5. Toothed belt drive: improved power transmission and smoother running
6. Central lubrication: easy maintenance
7. CNC axis: exact positioning of spindles
8. EMGS brake unit: maintenance-free, only 10 seconds to brake
9. Electric motor: energy saving IE-2 class drive motor

- Excellent concentric accuracy of spindles
- Long service life for individual components
- Strict quality control
- Over 700,000 WEINIG spindles in use worldwide
- WEINIG Quality

# Cast iron: The basis for excellent surface quality

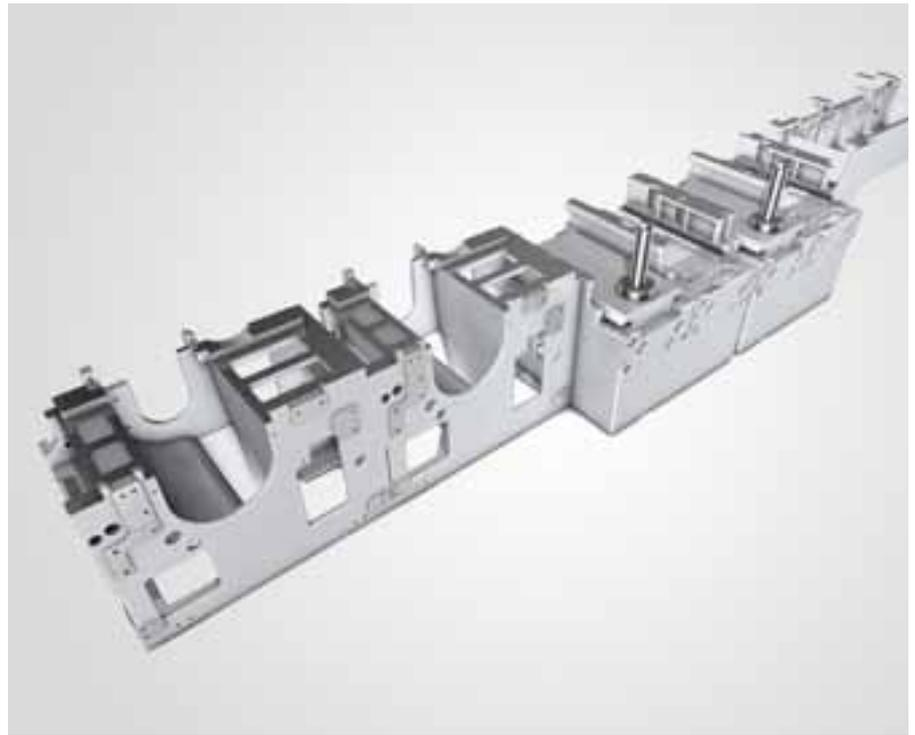

The very latest software programs are used in development (FEM/CAD-3D). The production process is monitored using latest technology measuring instruments. CNC machining in a single clamping step ensures ultimate precision.

- Heavy construction
- Minimum vibrations
- Extremely smooth running
- Superior surface quality
- Uniform cutter marks

A moulder isn't all that different from a house: a solid foundation ensures that your house isn't built on sand. However, the difference is that we have to deal with a large number of moving parts in the Powermat 1200. In order to be able to produce quality, smooth running is paramount. This is why the Powermat 1200 has a heavy, vibration absorbing cast iron base. This solid base allows the high quality components from WEINIG to demonstrate their superiority. The specific properties of cast iron and the stability of the machine base allow work pieces to be machined with ultimate accuracy and surface quality.

# WEINIG's table plate system: The ideal solution



With WEINIG's table plate system the table plate can be set to the tool radius quickly and easily. Minimal openings are the basis for good surfaces. The position of all adjustable table plates can be stored easily in PowerCom. Setup has never been so simple.

The segmental design of the WEINIG table plate system means that they can be replaced easily. Each table plate dimension is fully documented so parts can be replaced even years later.

## **MarathonCoating:**

- Long service life for the table plates
- Reduced friction
- Superior bonding (no flaking off)
- Very good corrosion resistance
- Ecologically responsible production process

# The original PowerLock system: Rapid tool change

When it was first introduced into the market it was a sensation; today it can be found everywhere quality is foremost. The original WEINIG PowerLock tool system The compact PowerLock cutterhead is light and extremely easy to change. The HSK interface is characterized by rigidity and excellent true running accuracy. Three tons of clamping force



PowerLock made easy: Press a button to release the cutterhead, remove it, insert a new cutterhead and press a button to clamp it. That's it. You won't see a moulder yet that you can retool quicker or easier than with WEINIG's PowerLock system.



combines the two components into a single perfect unit without any fit tolerance. Irrespective of your production capacity or application – with PowerLock you can achieve outstanding surface quality at speeds of up to 12,000 rpm. With PowerLock you can more than double your linear production per day, slash unit costs and shorten delivery times. Simply at the press of a button!



PowerLock is an open system: the HSK interface accepts conventional tools such as cutter heads, solid profile cutters or saws. Sometimes you may need an adapter.

# Guiding and controlling of work pieces: Our core skill



1. 3-roller infeed with driven table roller
2. Driven table roller, height adjustable
3. Opposing outfeed rollers
4. Pressure elements with pneumatic control
5. Pressure shoe with cassette system
6. Precision dowel guide

Special attention is placed in those areas where the workpieces are being guided and transported. The new improved design of the pointed tooth feed rollers reduce tooth penetration into the wood to a minimum and are self-cleaning. Our pneumatic pressure elements ensure highly accurate control of the workpiece. The table plates are coated with MarathonCoating so the workpiece slides over the table without being damaged. WEINIG's expertise can be seen and felt on the work piece. You will be delighted with the surface quality as well as the repeatable dimensional accuracy of the Powermat 1200.

# A range without limits: A solution for every application



WEINIG stands for solid wood expertise. But we can do much more. Other materials can also be processed on our moulders with the same high quality. For example, composites such as WPC (Wood-Plastic-Composite). Even plastic, aluminum, MDF or electrical hardboard are no problem for the Powermat 1200. With its high performance, precision and repeat accuracy it covers an extremely wide range of applications. Just contact us. We will be sure to have a convincing solution for your application.

Materials that can be processed by the Powermat 1200:

- WPC (Wood-Plastic-Composite)
- MDF
- Chipboard
- Electrical hardboard
- Plastics
- Foamed materials
- Cement boards
- Aluminum

# Original WEINIG feed rollers: It's the grip that counts



## **WEINIG CeraCoat roller**

A coated roller for highly abrasive materials. Abrasion-proof, long service life, no indentations

## **WEINIG Durofer steel roller, knurled**

The ideal roller for hardwood and panel production. Maximum grip but without surface marking, even under high pressure.

## **The new WEINIG pointed tooth roller 2.0**

Universal roller with maximum grip, more feeding power and longer service life with less debris build up.

Geometric alignment of teeth, contact surface, material properties – feed rollers are a science all on their own. With original WEINIG feed rollers you can be sure that your work pieces are transported optimally through the machine for every application.



**WEINIG Durofer steel roller, smooth**

The ideal roller for transporting work pieces with a finished surface. No indentations

**WEINIG roller, vulcanized rubber**

The ideal roller for profiled surfaces. Different vulcanized rubber mixtures with high wear resistance and high traction are available.

**WEINIG Durofer fluted roller**

The ideal roller for wet or exotic woods. High power transmission, long service life, self-cleaning.

# Greater utility: All-round machining and sawing in one workstep

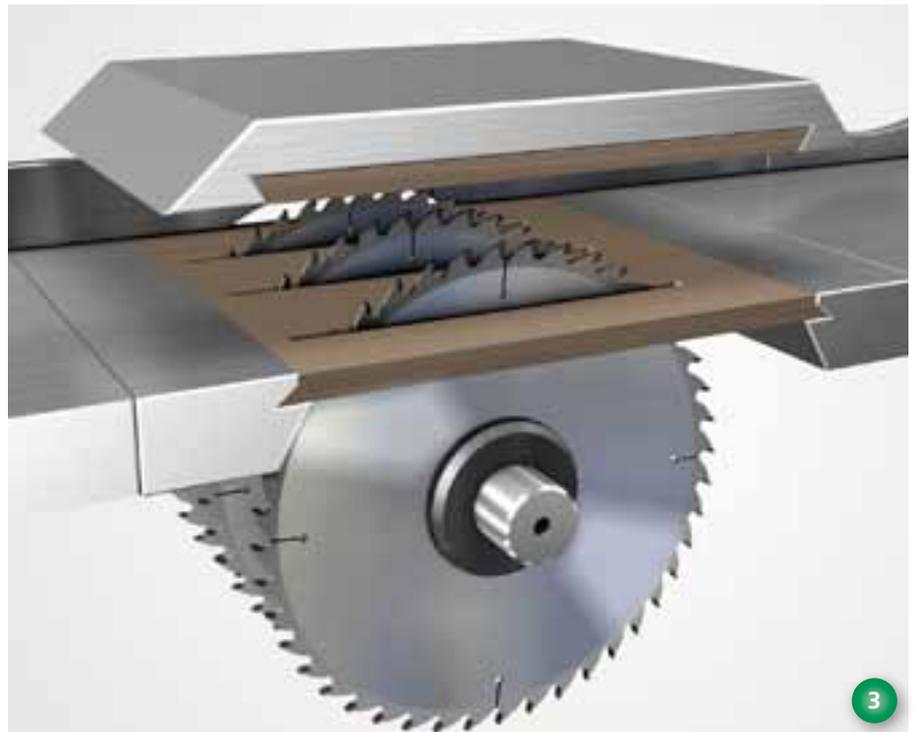
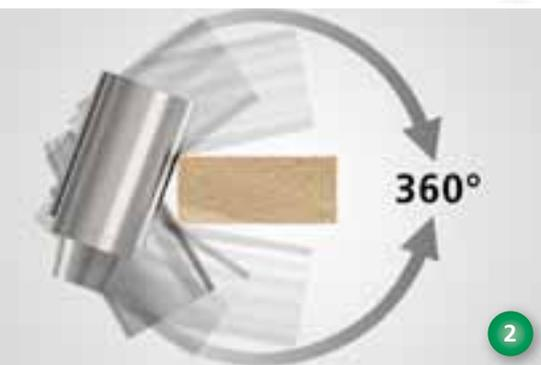

**1. T slot milling** – T slots and other high precision grooves can be profiled in one operation. With a universal spindle and a PowerLock cutterhead which can be positioned over a range of 360°.

**2. Universal spindle** – Do you often have complex profiles to produce? In that case the universal spindle would be a useful addition to your spindle arrangement. The universal spindle can be positioned over a range of 360° and can be used as an additional spindle on each side. It is excellently suited for grooves, kerfs and separating work pieces (savings in wood!).

**3. Ripping** – Planing, profiling and sawing in one operation? Not a problem for the Powermat 1200. The bottom spindle turns your machine into a multi-blade rip saw. The first bottom spindle creates a flat reference surface. The work piece is guided smoothly and accurately during ripping. This increases the service life of the sawblades.



**Splitting unit** – Profitable production of lamellas requires process reliability, short setup times and maximum wood yield. The Powermat satisfies these requirements ideally: The wood can be processed in one workstep; first by planing all 4 sides and then ripping. Resulting in high production capability. During this process the material is pressed flat against the guiding surfaces, resulting in significant savings in material.

In addition, the rigid design of the PowerLock system ensures excellent machining quality. Changing the saw adapter is as quick and easy to perform as changing the splitting wedge cassette system. Due to the integrated spray unit the sawblades are kept clean and cool running. This allows the use of thin kerf sawblades to increase the material yield. The splitting wedge is also available as a separate unit.



For more information,  
go to [film7.weinig.com](http://film7.weinig.com)

# The electrical system: Power from the cabinet

With the growing complexity of machines the requirements of the electrical system have soared. The switch cabinet has our full attention. For the sake of our customers, because we know: the better organized things are behind the doors, the more trouble-free the machine will run. Only qualified switch cabinet builders are employed in WEINIG's electrical assembly department. They ensure that the power is sent to the right receiver.



The designation of equipment is structured logically and arranged according to function. Each component in a WEINIG switch cabinet has a fixed designation. If a fault occurs, the WEINIG service team only needs the alpha-numeric name of the unit from the customer. An invaluable advantage which ensures that your machine will be quickly back in production.



Different countries have different standards and regulations. At WEINIG every machine we make conforms specifically to the regulations of the country it is being sent to.





The high tech electrics in our moulders are developed in close cooperation with international companies such as Siemens. For example, the new motor starter design resets its parameters according to the weight of a newly inserted tool and optimizes the load.



A faulty contact in the electrical system can cause the machine to shut down. WEINIG switch cabinets undergo a comprehensive functional test according to a checklist before leaving the assembly area. All working processes of the moulder are simulated.

# WEINIG's safety package: Much more than CE

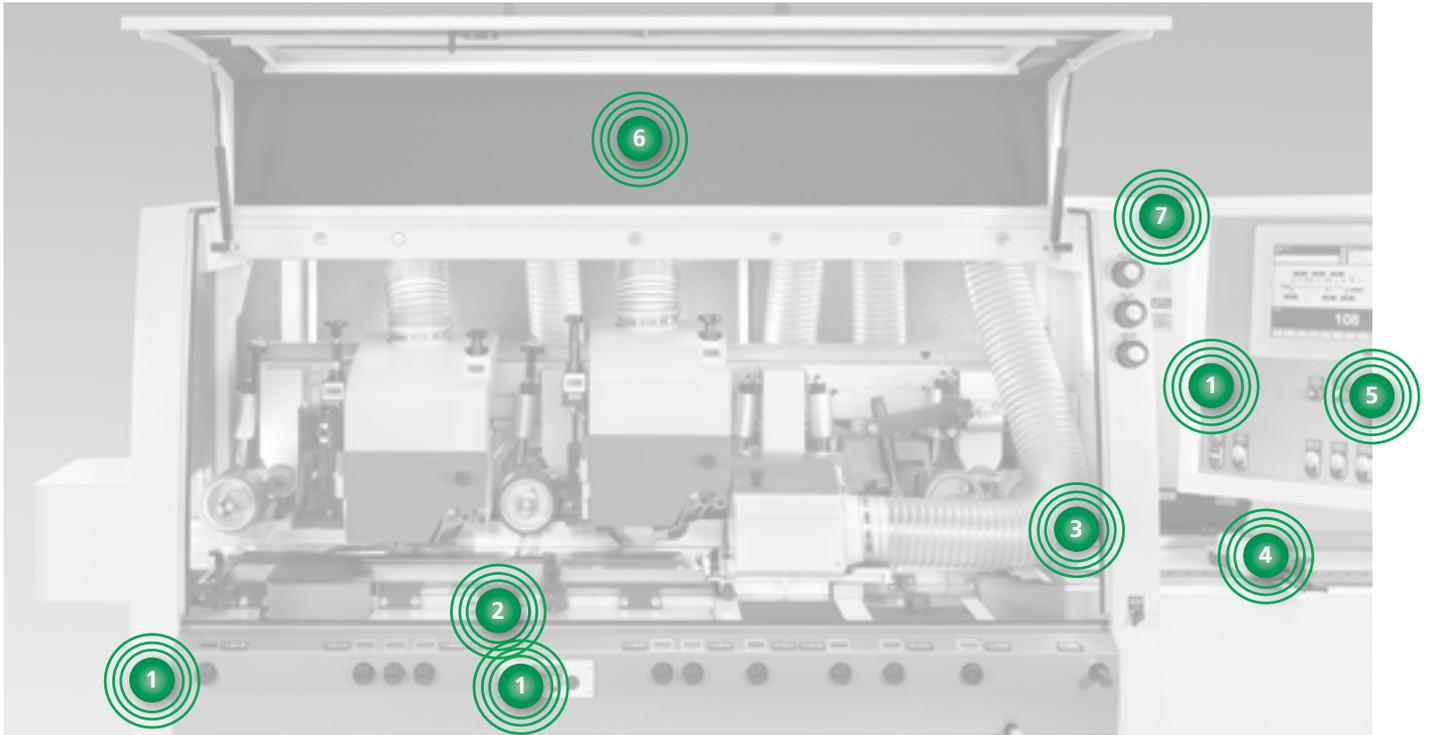

When it's a question of the safety of your machine and your employees, it is not enough to have a simple CE label stuck onto your machine. CE is good, but we are better. WEINIG supplies the Powermat 1200 with a comprehensive package for active and passive safety – a voluntary standard from WEINIG. This includes:

1. Emergency stop buttons
2. Electromagnetic lock for the safety cover
3. Infeed flap switch (for hand protection)
4. Anti kick-back device (optional for splitting)
5. Key switch for mode of operation: automatic, manual or setup
6. Full safety enclosure
7. Electronic spindle brakes

## WEINIG's lighting and inspection package: A clear view



The interior lighting in the Powermat 1200 is powered by high performance LEDs. The homogeneous full illumination mimics natural daylight to create excellent conditions for precise work and optimum results.

# Useful options: A clever decision



The Powermat 1200 is specially designed for high flexibility and can be equipped with many options. Your WEINIG expert will be pleased to help you decide to what degree a particular option makes sense or how other components can work together to make the machine even more efficient for your production needs.

## 1. Groove guide

The WEINIG groove guide is an ideal option for controlled processing of short and difficult to guide workpieces. The result is straight and accurate workpieces. Crooked or distorted workpieces are straightened on the face and edge. Tapered or curved workpieces can be planed to an exact thickness.

## 2. Mobile spindle

When processing random width material for; panels, stair treads or cabinet doors, the mobile spindle from WEINIG is an excellent choice. This multi-tasking unit automatically measures the width, moves the left spindle into position and processes the work piece to the maximum possible width. All in one cycle. It is

operated via the control system of your Powermat 1200.

## 3. Reduced feed roller spacing

This option guarantees continuous transport of short pieces through the machine while preventing snipes and improving straightness.

## 4. Table plate with guiding knife

A useful option to prevent snipes in short or thin workpieces in the area of the vertical tool holders. In addition straightening quality is improved. The work piece is stabilized and guided.

## 5. 2nd Right vertical tilting spindle

With this spindle it is possible to tilt up to 45 degrees to produce a bevel with a planing cutterhead. It is just



For more information,  
go to [film4.weinig.com](http://film4.weinig.com)



as easy to produce an undercut or an angled groove with this spindle.

#### 6. Bar code scanner

With a hand held scanner it is possible to read workpiece data from a bar code and transfer this to the PowerCom system. This ensures the machine settings match the work piece exactly. The perfect option for absolute process reliability for tracking and identifying parts. With PowerCom Plus it is possible to log machine and production data for efficiency evaluation.

#### 7. Textured surfaces

With rising demand for textured surfaces, it could be advantageous to be able to respond to this demand in your own production facility. Parameters are entered and stored

in PowerCom. The complexity of the surface structure can be increased by using multiple spindles or making multiple passes.

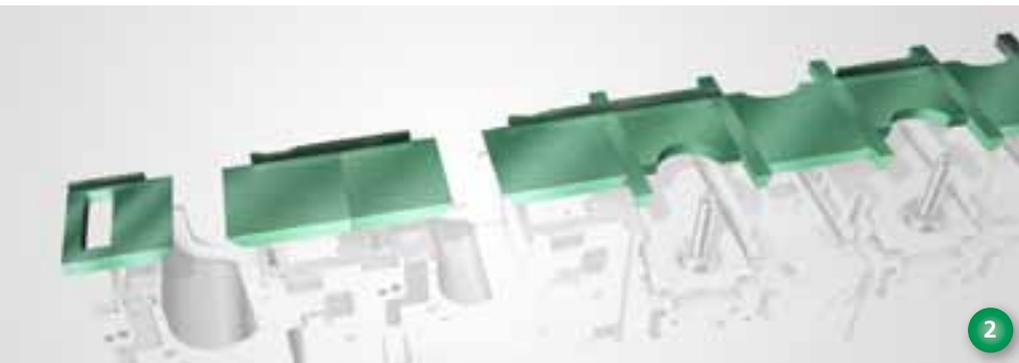

### 1. Reinforced suction hose

Splinters can pierce the suction hose and cause damage. The suction hose with reinforced outer wall prevents such damage and also offers a long service life.

### 2. MarathonCoating

This special coating protects the machine table, fences and pressure elements from excess wear. This option is to be recommended especially when processing abrasive materials such as tropical woods or MDF. There are three types of coatings available: MarathonCoating, MarathonPowerCoating and MarathonCoating Plus. The production process uses an environmentally friendly technology which does not generate any waste material.

### 3. Hardboard table inserts

Table inserts can be sawn through with sawblades, providing a continuous surface for the workpiece. This offers the advantage of improved tolerances of the lamellas and less tear-out in the area where the sawblades exit the workpiece. Short workpieces cannot drop into the table opening and cause jamming. The pressure shoe with hardboard insert ensures that sawblades will not be damaged while ripping.

### 4. Automatic Waxilit pump

This option allows you to optimize the amount of lubricant required to prevent resin build-up support continuous transport of workpieces. The volume of lubricant and the intervals of application can be controlled by



5



6



7



8



9

PowerCom according to the particular requirement.

#### 5. Cassette system

The cassette system for counter profile shoes and special guides provides equal pressure at multiple points over the profile contour. This offers the advantages of improved surface quality and an enormous saving in setup times because the cassette is quick and simple to insert and clamp. A stop screw ensures that once the counter profile shoe has been set it will always reset to the same position.

#### 6. Adjustable pressure bars

Various sizes available for different profile depths.

#### 7. Setting stand for cassettes

This option allows you to quickly and easily pre-set the pressure bars on counter profile cassettes according to a wood sample or templates.

#### 8. Assembly stand for PowerLock tools

Located in the grinding room, this option is used to ensure safe break-down and build-up of cutterheads as well as accurate positioning of the knives.

#### 9. Counter profile shoe

For limited applications a solid counter profile shoe can be self-made or purchased from WEINIG.



**1. Universal spindle**

The universal spindle increases your flexibility enormously because it can be used in 360 degree operation. Complex profiles and undercuts can be performed easily in one operation.

**2. Router application**

T-slots and other precision grooves can be profiled in one operation. For this purpose a universal spindle with PowerLock and a router bit with HSK adapter are used.

**3. Improved sound insulation**

The machine enclosure is reinforced with a multi-layer construction having a thickness of around 85 mm (3.35"). This means a noise reduction of ca. 15 dB can be achieved.

**4. Motorized positioning of the infeed fence and infeed table**

A rheostat switch and LED display allow positioning accuracy of 0.1 mm.

**5. Climate control unit for switch cabinet**

This option protects the electrical switching gear from extreme temperatures and moisture condensation. It serves as a cooler unit for ambient temperatures above 40° C. Or as a heater to prevent failure of electronic components at temperatures of 5° C and below. Climate control is also available for the separate operating panel with touchscreen.



**6. Operating panel separate from switch cabinet**

A stand-alone operating panel makes sense if space allows. It offers better viewing and quicker access while performing set-ups.

**7. Switch cabinet and operating panel separate from the machine**

This option allows the switch cabinet to be placed in a position where it does not conflict with material handling equipment or obstacles in the work area. Required for machines with 8 spindles or more! Cable length of switch cabinet to machine is 2.5 m (8.2').

# The WEINIG system: Integrated organization of the machine infrastructure

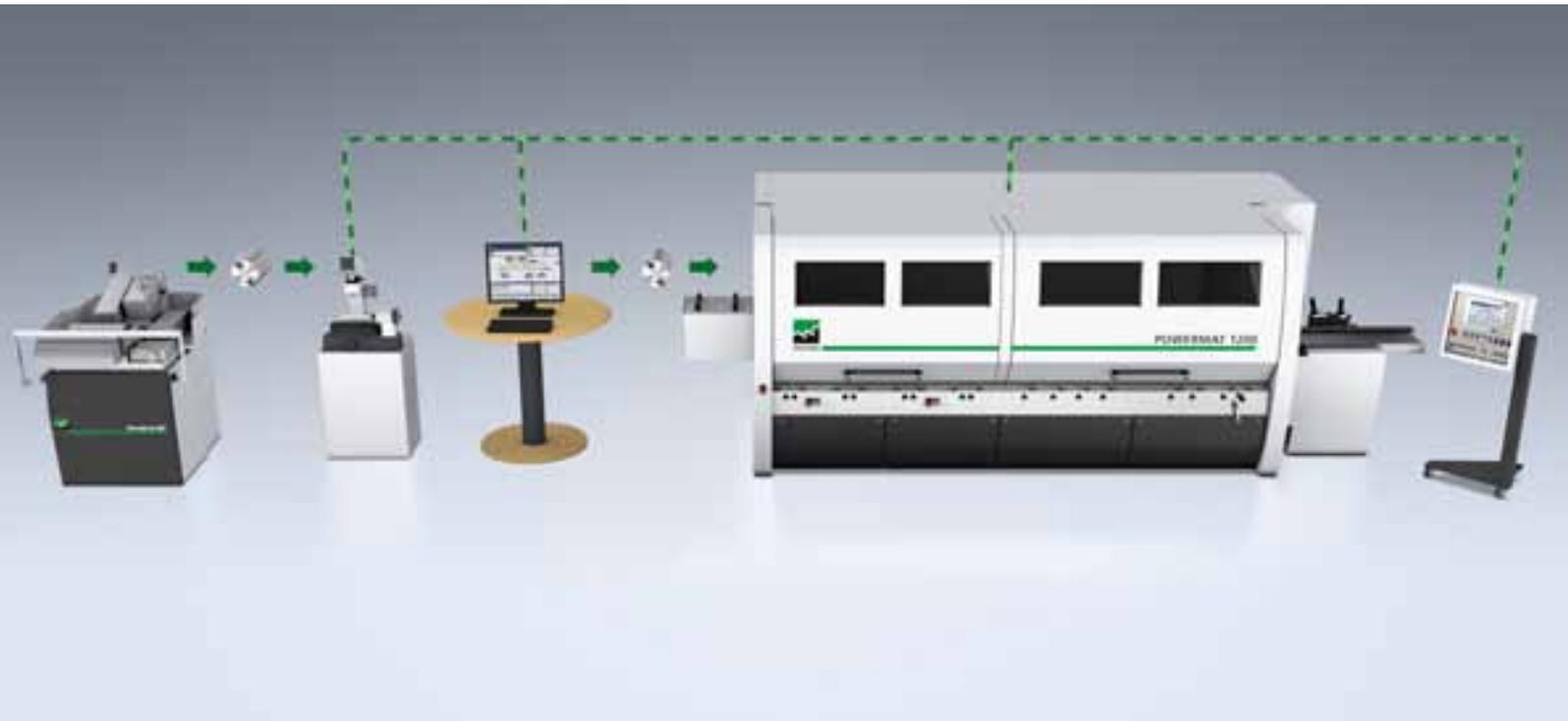

The WEINIG System enhances your Powermat 1200 to become a highly efficient machining center that raises productivity. The individual system modules fit together like building blocks to produce the perfect result. From tool preparation to moulder set-up. You can grind your own profile knives and re-sharpen them efficiently with the Rondamat 960. The advantages for you: this makes you independent from tool services and shortens your delivery times. The OptiControl measuring system and PC located in your tool room are used to determine tool measurements and enter profile data. This information is automatically transferred and saved in the PowerCom PC at the moulder. The digital readouts already display the target setting at all digital readouts. With CNC axes everything moves into position at the press of a button. So simple, fast and repeatable at any time - that is production with the WEINIG system!

# The control systems: Three for each individual requirement

## PowerCom Plus

- Multiple machine control system
- Machine and production data
- Tool and profile management
- Number of profiles 10,000
- Workshop system
- Production and order optimization
- User management
- OptiControl PC linked to moulder PC



## EasyCom

- Workpiece oriented
- Stand-alone machines
- Tool and profile management
- Storing additional values
- Number of profiles 2,000
- Central control motor startup
- Control panel can be pivoted to the operating area
- Rulers on adjustable components reduce set up time



## Memory Plus

- Teach-in oriented
- Stand alone machines
- Number of profiles Up to 500 profiles
- Profile administration



# PowerCom Plus: Networked with your environment

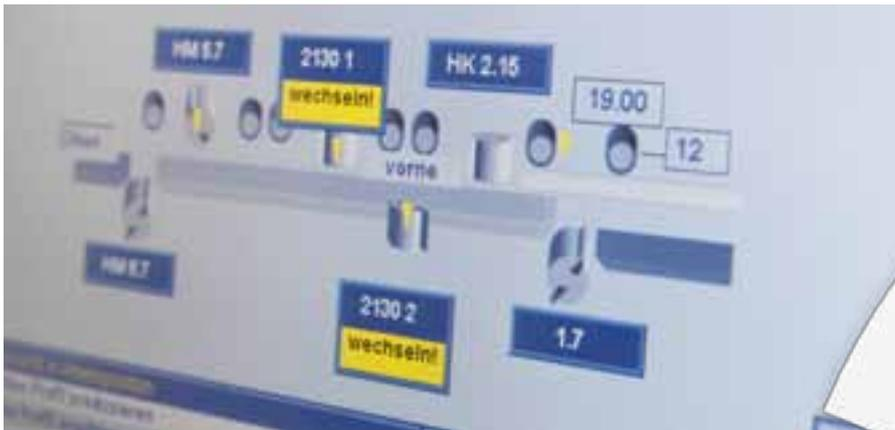

PowerCom displays all important system information at a glance. User-friendly touch-screen. The control system gives you access to the data of up to 15 machines. You can position any number of axes automatically at the touch of a button. Documentation of operating and machine data gives you the ability to optimize your production.

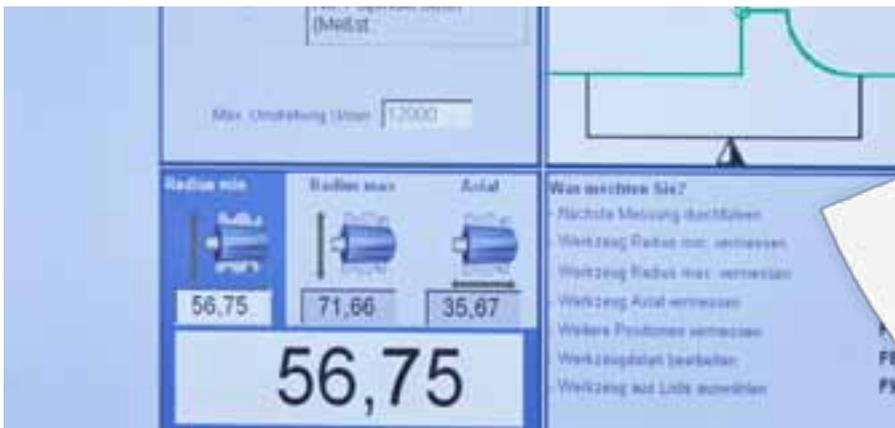

Those who are measuring tool dimensions have taken a decisive step toward work-piece precision and reduced setup times. OptiControl allows you to determine tool measurements with ease. Data are sent on-line to the control system. This makes machine setup child's play.

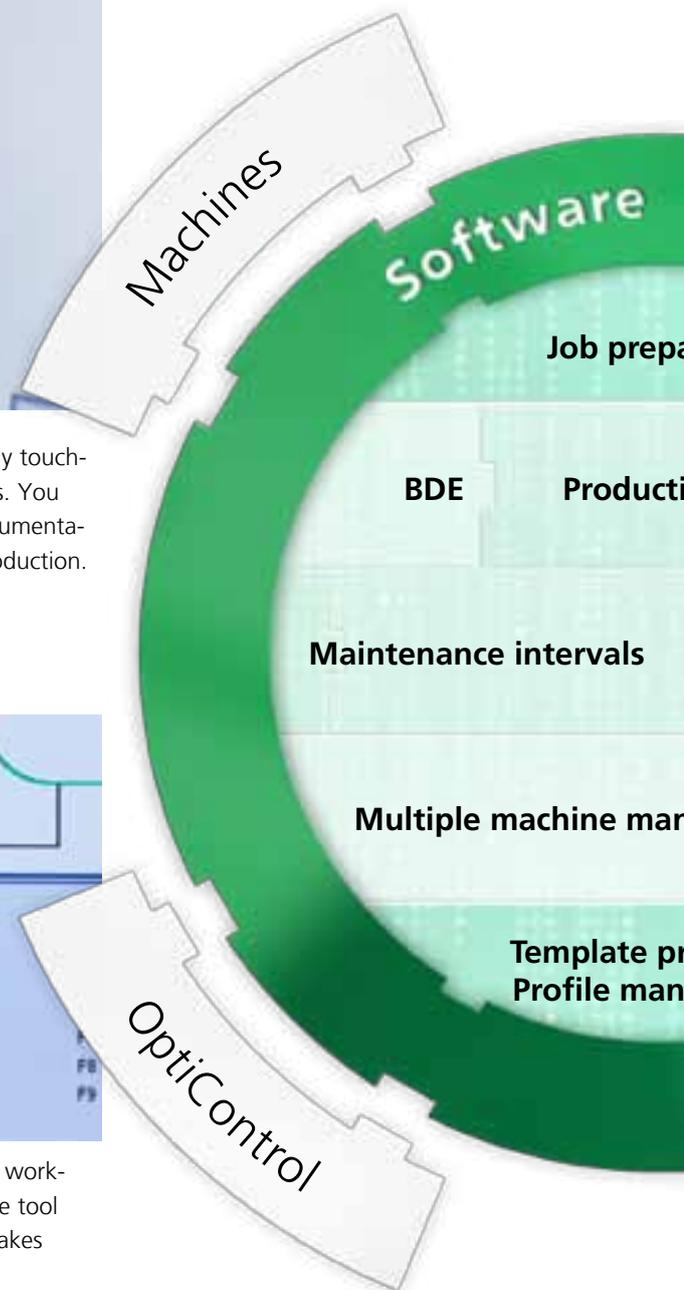

ODC = operating data capture

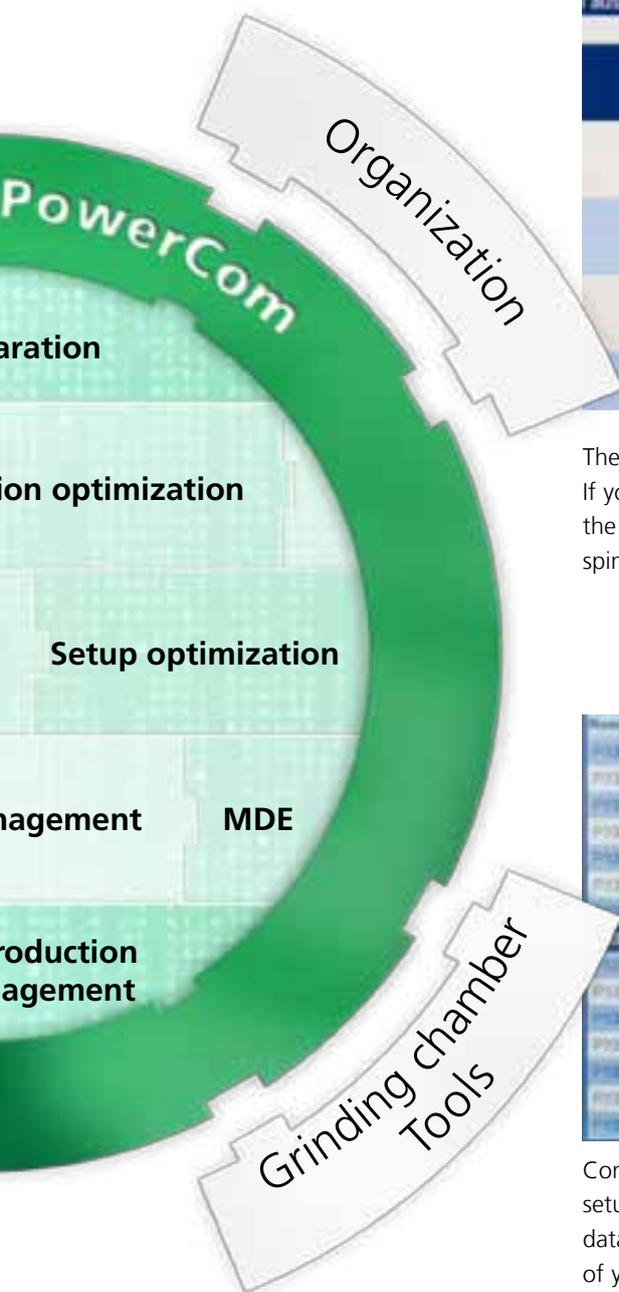

auswählen	Symbol	Bezeichnung	Gruppe	Typ
2090		Riffel fein unten 67/71/75 Breite: 150.00 Höhe: 25.00	0	
2130		Flanset (Feder 5 mm) Breite: 70.00 Höhe: 19.00	0	
2462		Handlauf Breite: 50.00 Höhe: 45.71	0	
3014		Venenprofil (Treppe) Breite: 65.00 Höhe: 42.00	0	
3050		Venenprofil Breite: 70.00 Höhe: 19.00	0	

The software enables you to manage up to 10,000 profiles and data for 10,000 tools. If you want to produce a certain profile, the data is at your fingertips for retrieval from the archive. The settings are shown on a digital display on the adjustment axes of the spindles and ensure exact reproducibility of your work piece.

Rechner	Startzeit	Programm Start	Programm Ende	Proj. Laufzeit	Aktuell	Summe
P1000	26/02/11	7/12/2011 6:40:51 AM	7/12/2011 4:14:20 PM	3.50 h		
P1000	27/02/11					
P1000	28/02/11					
P1000	29/02/11					
P1000	01/03/11					
P1000	02/03/11					
P1000	03/03/11					
P1000	04/03/11					
P1000	05/03/11					
P1000	06/03/11					
P1000	07/03/11					
P1000	08/03/11					
P1000	09/03/11					
P1000	10/03/11					
P1000	11/03/11					
P1000	12/03/11					
P1000	13/03/11					
P1000	14/03/11					
P1000	15/03/11					
P1000	16/03/11					
P1000	17/03/11					
P1000	18/03/11					
P1000	19/03/11					
P1000	20/03/11					
P1000	21/03/11					
P1000	22/03/11					
P1000	23/03/11					
P1000	24/03/11					
P1000	25/03/11					
P1000	26/03/11					
P1000	27/03/11					
P1000	28/03/11					
P1000	29/03/11					
P1000	30/03/11					
P1000	31/03/11					
P1000	01/04/11					
P1000	02/04/11					
P1000	03/04/11					
P1000	04/04/11					
P1000	05/04/11					
P1000	06/04/11					
P1000	07/04/11					
P1000	08/04/11					
P1000	09/04/11					
P1000	10/04/11					
P1000	11/04/11					
P1000	12/04/11					
P1000	13/04/11					
P1000	14/04/11					
P1000	15/04/11					
P1000	16/04/11					
P1000	17/04/11					
P1000	18/04/11					
P1000	19/04/11					
P1000	20/04/11					
P1000	21/04/11					
P1000	22/04/11					
P1000	23/04/11					
P1000	24/04/11					
P1000	25/04/11					
P1000	26/04/11					
P1000	27/04/11					
P1000	28/04/11					
P1000	29/04/11					
P1000	30/04/11					
P1000	01/05/11					
P1000	02/05/11					
P1000	03/05/11					
P1000	04/05/11					
P1000	05/05/11					
P1000	06/05/11					
P1000	07/05/11					
P1000	08/05/11					
P1000	09/05/11					
P1000	10/05/11					
P1000	11/05/11					
P1000	12/05/11					
P1000	13/05/11					
P1000	14/05/11					
P1000	15/05/11					
P1000	16/05/11					
P1000	17/05/11					
P1000	18/05/11					
P1000	19/05/11					
P1000	20/05/11					
P1000	21/05/11					
P1000	22/05/11					
P1000	23/05/11					
P1000	24/05/11					
P1000	25/05/11					
P1000	26/05/11					
P1000	27/05/11					
P1000	28/05/11					
P1000	29/05/11					
P1000	30/05/11					
P1000	31/05/11					
P1000	01/06/11					
P1000	02/06/11					
P1000	03/06/11					
P1000	04/06/11					
P1000	05/06/11					
P1000	06/06/11					
P1000	07/06/11					
P1000	08/06/11					
P1000	09/06/11					
P1000	10/06/11					
P1000	11/06/11					
P1000	12/06/11					
P1000	13/06/11					
P1000	14/06/11					
P1000	15/06/11					
P1000	16/06/11					
P1000	17/06/11					
P1000	18/06/11					
P1000	19/06/11					
P1000	20/06/11					
P1000	21/06/11					
P1000	22/06/11					
P1000	23/06/11					
P1000	24/06/11					
P1000	25/06/11					
P1000	26/06/11					
P1000	27/06/11					
P1000	28/06/11					
P1000	29/06/11					
P1000	30/06/11					
P1000	01/07/11					
P1000	02/07/11					
P1000	03/07/11					
P1000	04/07/11					
P1000	05/07/11					
P1000	06/07/11					
P1000	07/07/11					
P1000	08/07/11					
P1000	09/07/11					
P1000	10/07/11					
P1000	11/07/11					
P1000	12/07/11					
P1000	13/07/11					
P1000	14/07/11					
P1000	15/07/11					
P1000	16/07/11					
P1000	17/07/11					
P1000	18/07/11					
P1000	19/07/11					
P1000	20/07/11					
P1000	21/07/11					
P1000	22/07/11					
P1000	23/07/11					
P1000	24/07/11					
P1000	25/07/11					
P1000	26/07/11					
P1000	27/07/11					
P1000	28/07/11					
P1000	29/07/11					
P1000	30/07/11					
P1000	31/07/11					
P1000	01/08/11					
P1000	02/08/11					
P1000	03/08/11					
P1000	04/08/11					
P1000	05/08/11					
P1000	06/08/11					
P1000	07/08/11					
P1000	08/08/11					
P1000	09/08/11					
P1000	10/08/11					
P1000	11/08/11					
P1000	12/08/11					
P1000	13/08/11					
P1000	14/08/11					
P1000	15/08/11					
P1000	16/08/11					
P1000	17/08/11					
P1000	18/08/11					
P1000	19/08/11					
P1000	20/08/11					
P1000	21/08/11					
P1000	22/08/11					
P1000	23/08/11					
P1000	24/08/11					
P1000	25/08/11					
P1000	26/08/11					
P1000	27/08/11					
P1000	28/08/11					
P1000	29/08/11					
P1000	30/08/11					
P1000	31/08/11					
P1000	01/09/11					
P1000	02/09/11					
P1000	03/09/11					
P1000	04/09/11					
P1000	05/09/11					
P1000	06/09/11					
P1000	07/09/11					
P1000	08/09/11					
P1000	09/09/11					
P1000	10/09/11					
P1000	11/09/11					
P1000	12/09/11					
P1000	13/09/11					
P1000	14/09/11					
P1000	15/09/11					
P1000	16/09/11					
P1000	17/09/11					

# EasyCom: Work piece-oriented user guidance

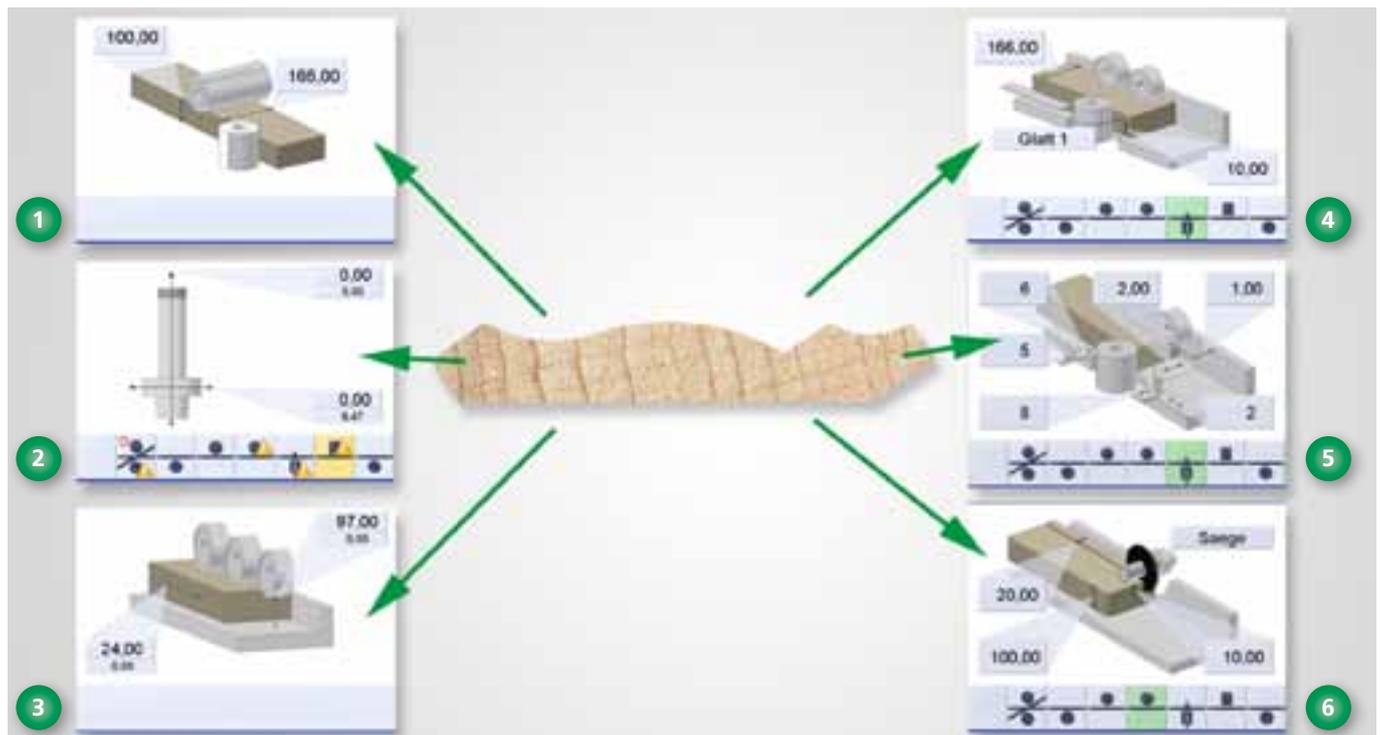

Examples for the GUI

1. Easy dimension change (ATP)
2. Positioning of spindles radially and axially
3. Setting for feed height and speed
4. Positioning of the left spindle in relation to work piece width
5. Setting table plates, pressure units and edge jointing fences
6. Positioning / activation of saws from above

EasyCom is a compact PC control system with work piece-oriented user guidance directly on the Powermat 1200 and intuitive operation via touchscreen. You will be amazed how easy it is. At a glance you get clear information and understandable documentation on the current setup of of each component in your Powermat 1200. The terminal can be easily pivoted to the operating area. EasyCom enables you to manage the tools on your machine, enter new tool data after sharpening and store additional settings with ease. During planing, a quick change of width and thickness can be done at the touch of a button. EasyCom increases the availability of your machine while helping you to improve work piece quality and making repeat set ups fast. Quality, delivery times and price – that's the way to win orders!

# Memory Plus: Machine management in a class of its own



The software was developed specially for dimensional planing with a constant tool cutting circle. Operating the control is self-explanatory. A touchscreen with clear digital displays and unique symbols offers a high level of convenience. With Memory Plus you can set work piece dimensions as quick as a flash. Tool radii are entered on the touchscreen. Tool radii are calculated automatically when regrinding. Up to 500 Profiles can be stored in a list. A screen display provides information on the tools required for each profile. The highly flexible Memory Plus allows you to control further applications, such as a mobile spindle and separating a glazing bead.

- Lightning-fast setting of work piece dimensions
- Operation via touchscreen
- Clear presentation, tool radii entry via touchscreen
- Required tools displayed for each profile
- Tool data calculated automatically after sharpening
- Correction mode for easy-to-make settings.
- Profile list with up to 500 profiles
- Further applications:
  - Mobile spindle
  - Rounding and chamfering
  - Separating glazing
  - Storing profiles after the teach-in process

# Original WEINIG tools: Quality tested top technology



1. Original WEINIG planning head 530 type with reversible knife system
2. Original WEINIG profile cutterhead type 503 with clamping screws
3. Original WEINIG profile cutterhead type 533 with CentroLoc

A chain is only as strong as its weakest link. Which is why you should rely on WEINIG for your tooling requirements. We have been making cutterheads since 1980 and can offer an ideal tool solution for every application and feed speed such as conventional, hydro or Powerlock clamping systems. The knife materials HSS, stellite or carbide and cutting geometries are adapted exactly to the requirements of your material. We set standards with bore tolerances of H7 quality and G1 balance quality for the production of tool bodies. and we can make you even more efficient with our tool grinder program Rondamat. The WEINIG system has one objective only: to create the conditions for you to supply perfect work pieces.

# PowerLock: Flexible and fast for high productivity



Long setup times cost time and money. With the original WEINIG PowerLock system you can set up in seconds and increase your productivity compared to standard tools. Press a button to release the cutterhead, remove it, insert a new cutterhead and press a button to clamp it. That's it. The immense rigidity of the monolithic HSK system makes high RPMs possible up to 12,000 rpm and offers excellent true running accuracy. Even with 300 mm (11.8") working width no out-board bearing is required. All of this without compromising surface quality. Irrespective of whether you want to produce small batches or long production runs.

PowerLock is available in varying options for a wide range of cutting systems, working widths and applications. This tool system is famous the world over and is produced strictly according to WEINIG's high quality standards

Various tools and accessory options are available on the basis of the PowerLock system:

1. Original WEINIG profile cutterhead type 539 with CentroLock
2. Original WEINIG Spiral planing cutterhead type 541
3. Original WEINIG planing cutterhead type 536 with reversible knives and Centroloc



For more information,  
go to [film3.weinig.com](http://film3.weinig.com)

# WEINIG knife grinding systems: More flexibility and independence



Grinding, sharpening and creating profiles with the Rondamat:

- **Rondamat 960**  
Manual production and regrinding of profiling and straight knives using templates, maximum true running accuracy, numerous options
- **Rondamat 980**  
Fully automated for regrinding straight planing knives and face grinding including finger joint knives.
- **OptiControl**  
Exact measurements of tools such as planing and profiling cutterheads, solid cutter heads and saw blades. The measurements are transferred to the machine.

The Rondamat tool grinder rounds off WEINIG's production system perfectly. Producing and regrinding knives yourself make you flexible and independent. You will profit by shorter setup times and higher productivity. You can create a profile template at 1:1 scale from a drawing or an existing profile. Using this template you can profile the knife blank in a few minutes on the Rondamat. With the appropriate grinding wheels you can produce and sharpen HSS, stellite or carbide knives. The OptiControl measuring system will then determine the tool and profile data you need. The values are automatically transferred to the machine's PC, which stores them and transmits them to the spindles via the PowerCom control system.

# PowerMech: Tailor-made performance



Thinking in terms of complete systems is considered in the development of WEINIG moulders right from the start. We have designed the PowerMech automation system for the Powermat 1200. Everything from a single source and adapted exactly to your needs, the PowerMech modules are the key to maximum profitability and top productivity. The functional units range from an infeed or outfeed system through scanning and conveying to packing and stacking. With the high level of automation you can decide how far you want to exploit the amazing capabilities of your Powermat 1200. The modular system is flexible and will grow with your needs. Whether fast throughput with less operators, linking several workstations, greater ease of use or more safety – PowerMech always offers a customized solution to fit around your Powermat.

The PowerMech system performs every task perfectly, both upstream and downstream of your Powermat:

- Destacking
- Feeding
- Buffering
- Visual grading
- Sorting
- Stacking packs
- Transporting
- Packing
- Stacking

...and much more



For more information,  
go to [film8.weinig.com](http://film8.weinig.com)

# WEINIG quality: The sum of many properties



Not many companies succeed in becoming a brand. WEINIG has succeeded in doing so. Trust plays a central role here. And the ability to prove this trust on a daily basis with our customer. We do this with quality. From product development to our supply of spare parts, from materials used to our world-wide service network. Based on employees noted for their expertise and passion for the product. Utmost care in assembling machines is part of this, as is continuous training. In order to maintain WEINIG's high standards we focus on vertical integration and independent quality management. Based on the world famous kaizen method, our production undergoes a continuous optimization process.

But WEINIG quality also means aligning production for the future with open machine systems, energy efficiency and sustainability. All these characteristics blend to create a product praised by our customers around the globe as outstanding. We call it 100% WEINIG quality.



For more information,  
go to [film6.weinig.com](http://film6.weinig.com)

# WEINIG service: Very close to customers



Customer relations are good. But we have a better word for it: WEINIG service. Supported by people who want to share their enthusiasm for wood with others. And when experts start talking together, a solution is not far away. This is why WEINIG service focuses on dialog with you, on outstanding training and a local support presence. The global WEINIG service network is so densely spread like no other in the sector. For you this means easy communication in your own language and rapid help. Whether by telephone or by a technician on site. We are here for you when you need it. You can order any spare part you need via the hotline for rapid delivery - even old models. You will be advised in detail by a professional WEINIG expert in your country. In our individually tailored training programs you can find out how to exploit the capabilities of your machine to the fullest extent. Our specialists are always open for your production tasks.

- Subsidiaries in all continents of the globe
- Local WEINIG expert who speaks your language
- Mobile team of over 300 service technicians
- Spare parts via the hotline
- Professional advice by specialists via the hotline
- 6 day service
- Individually tailored training program
- Service agreements on request
- International ExpoCenter
- Financing to suit your needs

# Technical data

WEINIG planers and moulders offer a variety of spindle configurations. This means they can be specified perfectly to your particular application. The spindle sequences shown do not cover all options offered by our flexible systems by any means. Your WEINIG expert will be happy to advise you.

Please note: The dimensions given here are the values for a standard machine. Other configurations are possible with options such as improved sound insulation, a longer straightening table or modified position of the control cabinet, for example.

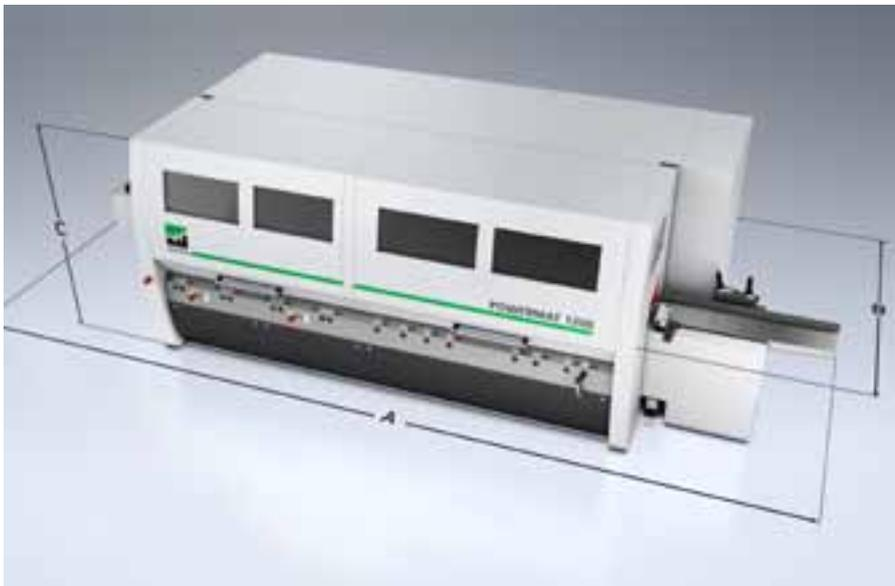

## Universal spindle

A useful addition for the production of complex profiles in one pass. Can be used in a wide range of applications and combined with other spindle configurations.



017

A = 3,870 mm (142.5"), B = 2,125 - 2,200 mm (72.4" - 84.2"),  
C = 1,740 mm (65")



018

A = 4,560 mm (142.5"), B = 2,125 - 2,200 mm (72.4" - 84.2"),  
C = 1,740 mm (65")



019

A = 4,320 mm (142.5"), B = 2,125 - 2,200 mm (72.4" - 84.2"),  
C = 1,740 mm (65")



010

A = 4,650 mm (142.5"), B = 2,125 - 2,200 mm (72.4" - 84.2"),  
C = 1,740 mm (65")



A = 800 mm (30.71"), B = 2,125 - 2,200 mm (72.4" - 84.2"),  
C = 1,740 mm (65")



026

A = 5,580 mm (142.5"), B = 2,125 - 2,200 mm (72.4" - 84.2"),  
C = 1,740 mm (65")



027

A = 4,800 mm (142.5"), B = 2,125 - 2,200 mm (72.4" - 84.2"),  
C = 1,740 mm (65")



013

A = 5,100 mm (142.5"), B = 2,125 - 2,200 mm (72.4" - 84.2"),  
C = 1,740 mm (65")



A = 1,000 mm (142.5"), B = 2,340 - 2,415 mm (72.4" - 84.2"),  
C = 1,740 mm (65")



A = 820 mm (30.71"), B = 2,125 - 2,200 mm (72.4" - 84.2"),  
C = 1,740 mm (65")

### Vertical Splitting unit

Planing and separating in one process. The cleaving unit ensures top performance in production.

### Horizontal splitting spindle

The bottom spindle turns the Powermat 1200 into a multi-blade rip saw. The work piece is moved smoothly and accurately during ripping.

# Technical data

Working height min./max.	10/160 mm (0.39" -6.29")
Working width min./max.	20/230 mm (0.78" -9.05")
260 mm (10.23") working width	○
200 mm (6.3") working height	○
300 mm (11.8") working width without outboard bearing in combination with the PowerLock	○
6,000 rpm	●
8,000 rpm	○
12,000 rpm	○
Memory Plus	●
EasyCom	○
PowerCom Plus	○
Electronic read-outs on spindle radial and axial, chip breaker and pressure shoe	●
CNC-controlled axis adjustments including feed beam and universal spindle	○
Receding chipbreaker, pneumatic	●
Max. Horizontal tool diameter (not first bottom)	225 mm (8.85")
Max. Vertical tool diameter and horizontal top	200 mm (7.87")
PowerLock tool holders	○
Universal tool holders	○
Frequency controlled feed speed (standard)	5 - 36 m/min
MarathonCoating for machine tables	○
Max. motor power on vertical spindle (standard option)	5.5 - 15 kW
Max. motor power on horizontal spindles (standard option) - not first bottom (max. 22 kW)	5.5 - 37 kW
Improved sound enclosure	○

● Standard    ○ Option

Subject to technical alterations. The statements and pictures provided in this brochure also include optional equipment that is not included in standard delivery. Some protective covers were removed for photographing.





MICHAEL WEINIG AG  
Weinigstrasse 2/4  
97941 Tauberbischofsheim  
Germany

Telephone +49 (0) 93 41 / 86-0  
Fax +49 (0) 93 41 / 70 80  
Email [info-profiling@weinig.com](mailto:info-profiling@weinig.com)  
Internet [www.weinig.com](http://www.weinig.com)